

# F=200 Tube lens system

## MS-200-TWL/TCD18

### 3 wavelength compatible Infinity Coaxial Tube Lens

f=200mm Coaxial Tube Lens / L shape Tube Lens

MS-200 tube lens system is a compact video microscope system with a coaxial illumination port designed for integration to the system. There are variations for single objective lens, right angle and manual / motorized turret system. Available for NUV, Visible, NIR and SWIR wave-lengths. Maximum image circle up to 1.1 inch with C mount. SEIWA DUV Plan, NUV Plan, Visible M.Plan APO, NIR M.Plan APO, and PE IR Plan series objective lenses are available for this system. In addition, Laser auto focus unit with motorized Z actuator version is available .

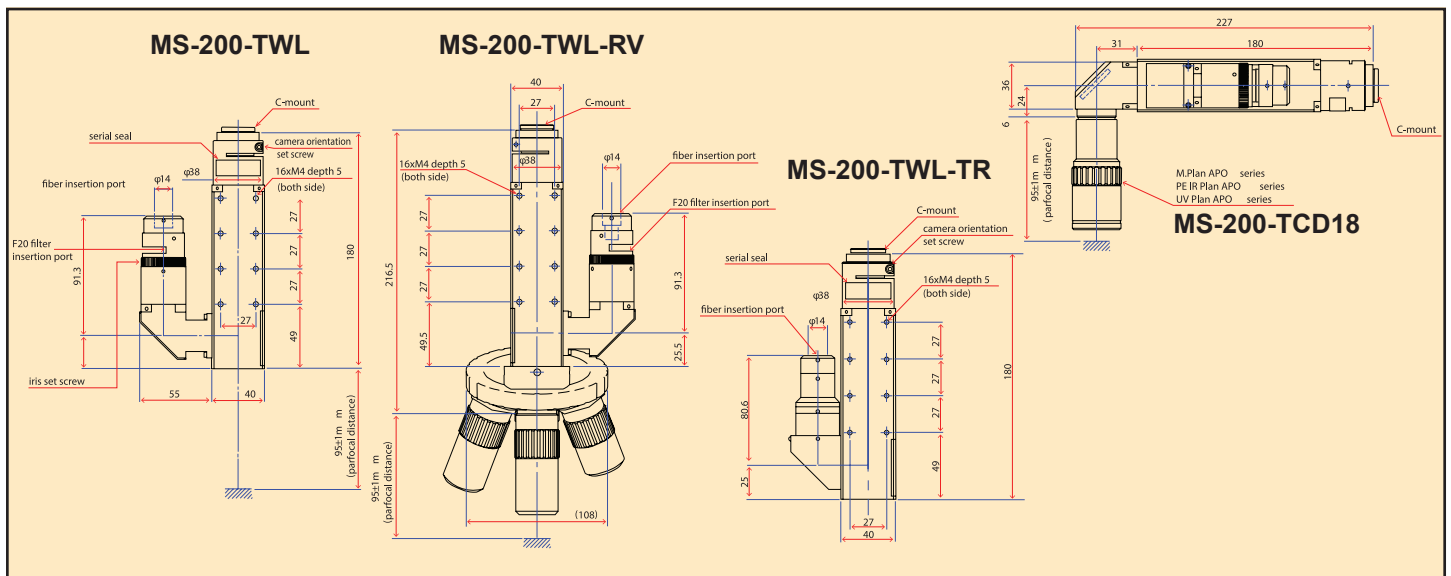

**Seiwa Optical America Inc**

3000 Scott Blvd,#203  
Santa Clara, CA 95054

**Tel :** +408-844-8008

**Fax :** +408-844-8944

**E-mail:** info@seiwaamerica.com

**http://**www.seiwaamerica.com